

# Active noise control in agricultural machines

K. Gulyas, G. Pinte, F. Augusztinovicz, W. Desmet, P. Sas

KULeuven, Department of Mechanical Engineering,

Celestijnenlaan 300 B, B-3001, Heverlee, Belgium

e-mail: [gregory.pinte@mech.kuleuven.ac.be](mailto:gregory.pinte@mech.kuleuven.ac.be)

## Abstract

Agricultural machines generate a complex noise field with significant low-frequency components. The demands for good sound comfort of the driver inside cabins of these machines are continuously growing. Since passive control techniques are not able to efficiently reduce the low-frequency noise in the cabin, active noise control techniques are being explored. A zone of quiet around the ears of the driver is quested through the use of secondary loudspeakers. This paper studies three different control strategies: feedforward control, feedforward control with feedback compensation and feedback control. The practical setup and the control algorithm of each control technique is discussed. The practical results, the advantages and the restrictions of the three techniques are compared.

## 1 Introduction

In recent years, the acoustical comfort of the driver has become a determining factor for the commercial success of agricultural machines. In this framework, the characteristics of agriculture interior noise have been subject of various studies [1], [2]. The interior noise in the cabin can be divided in two parts, depending on the sort of dynamic cabin excitation, that generates the noise, i.e. air-borne and structure-borne noise.

The air-borne part of the interior noise is caused by noise that impinges on the exterior of the cabin and consequently generates cabin vibrations, which transmit the sound to the interior. The engine is a typical example of a source of air-borne noise. Cabin vibrations, excited by forces which are transmitted to the cabin through the suspension, radiate the structure-borne part of the interior noise.

Passive noise control is the traditional technique to reduce the interior noise level. The use of well-chosen insulation materials can reduce the noise level significantly. In this framework, numerical models of the cabin, predicting the acoustic behaviour, are used to optimise the cabin design. The development of these numerical tools was the subject of some recent studies [3], [4].

The passive control techniques are very efficient for the reduction of the high-frequency components, but are not sufficient to reduce the low-frequency part of the interior noise [5]. This paper compares active



Figure 1: A photo of the harvester machine used for the active noise control experiments

noise control (ANC) techniques, that are used to attenuate the low-frequency noise (below 150 Hz) in the cabin of a harvester machine (figure 1).

The noise field, generated by this machine, is very complicated. The noise is radiated by different parts of the machine. The machine operates normally in 2 conditions. In road driving condition, the main part of the noise in the cabin appears at frequencies that are harmonics of the rotational speed of the motor. When the straw shaker and the front tools are switched on (normal working condition), higher peaks at other frequencies show up in the spectrum of the cabin noise and are more significant than the peaks caused by the motor. The active noise control experiments in this

study are executed on a stationary harvester machine, when the motor and all the tools are switched on.

Different active noise control strategies are considered. In a first part, feedforward control is studied. The achievable noise attenuation is strongly dependent on the coherence of the reference signal and the noise. Different possible reference signals outside the cabin are compared. In a second part, noise inside the cabin, which has a good coherence with the noise at the ears, is used as a reference signal. Because the sound, generated by the secondary loudspeakers, is also present in the reference signal, feedback compensation is necessary. The last part of the paper deals with feedback control. In this case, the time delay between the secondary loudspeakers and the error microphones restricts the achievable attenuation.

## 2 Feedforward control

This section discusses the results of a multiple-channel feedforward control system for the harvester machine. A  $1 \times 2 \times 2$  (one reference signal, two secondary sources, two error microphones) system was used for experiments. Two loudspeakers situated left and right behind the driver's seat, were used to reduce the noise level at two error microphones close to the ears of the driver. The well-known filtered-X LMS algorithm [6] was used as adaptive algorithm. This algorithm processes the reference signal, coherent with the noise at the error microphones, and the signals from the error microphones to calculate the appropriate anti-noise signal for the secondary loudspeakers.

The algorithm itself was implemented on a dSPACE 1103 DSP board by means of the developer software package ControlDesk [7]. The controlling programs were written in C language.

### 2.1 Comparison of reference signals

The quality of the reference signal determines the success of the feedforward control, i.e. the reference signal must be well correlated with the noise inside the cabin. Good coherence and consequently good reference signals can be found on those parts of the machine, which are responsible for large parts of the noise spectra inside the cabin. These main noise sources were searched on the basis of sound intensity scans around the whole harvester machine and measurements of the coherence between the radiated noise and the noise inside the cabin.

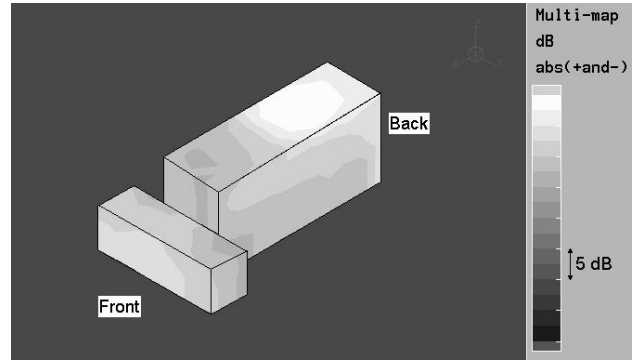

Figure 2: A sound intensity scan around the whole machine (octave band of 125 Hz)

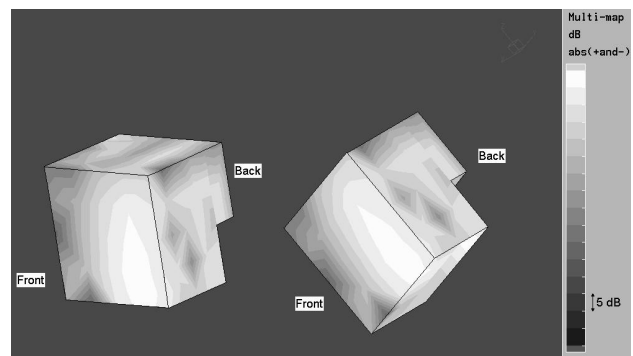

Figure 3: A sound intensity scan inside the cabin (octave band of 125 Hz)

Figure 2 shows an intensity scan of the noise around the harvester machine at the frequency range of interest (the octave band of 125 Hz, because this is the main part of the noise spectra inside the cabin). The high sound radiation at the front and the back of the machine indicates that the front tools and the motor are the main sources of the low-frequency noise, generated by the machine.

An intensity scan inside the cabin (figure 3) shows that most of the noise enters the cabin through the lower part of the front window and through the floor. The front tools generate the main part of the noise that enters the cabin because the front tools are closer to the front window and the floor of the cabin than the motor.

Simultaneously, the noise spectra were measured at different positions around the machine and inside the cabin. These measurements showed that the best coherence with the noise inside the cabin was found near the front tools. A measurement of the coherence near the front tools and the coherence at a different place (near the motor) is represented in figure 4. The reasonably good coherence near the front tools, especially at some important peak frequencies of the noise

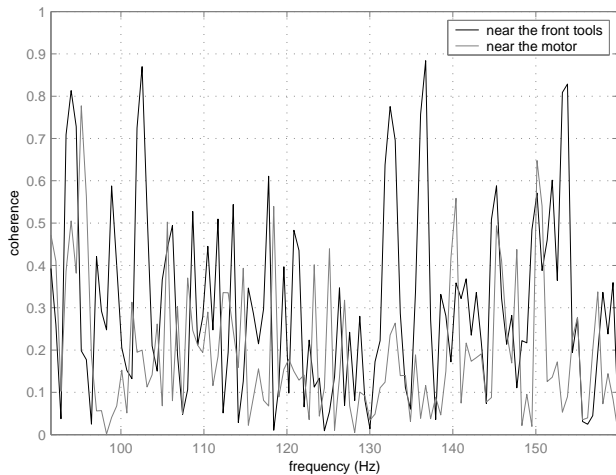

Figure 4: The coherence of the noise near the front tools and near the motor with the noise in the cabin

spectrum in the cabin, indicates that the front tools are responsible for the main part of the noise inside the cabin.

Different possible reference signals, related to the front tools, were compared: signals on the noise source (accelerations at different positions on the front tools, microphone signals near the front tools) and signals on the transmission path of the noise to the cabin (accelerations on the front window, microphone signals near the lower part of the front window and under the floor of the cabin). The remaining time necessary for the control action was sufficient for all these considered reference signals, even for those close to the cabin. The coherence with the noise inside the cabin was better for the signals on the transmission path close to the cabin. The best coherence was found in the microphone under the floor of the cabin near the front window. This is exactly the position where the main part of the noise enters the cabin, as shown in the intensity scan of the cabin.

Because the signal from the microphone under the floor had the best coherence, it was chosen as the reference signal for the feedforward control algorithm. This reference signal was filtered by a high ( $70 \text{ Hz} >$ ) and a low ( $< 300 \text{ Hz}$ ) pass filter to avoid control effort in the non-problematic frequency range. The convergence factor of the filtered-X LMS algorithm was set to 0.008.

## 2.2 Results

This paragraph deals with the results of the feedforward control. The investigation focused on the low-frequency range 90-150 Hz because that region is the

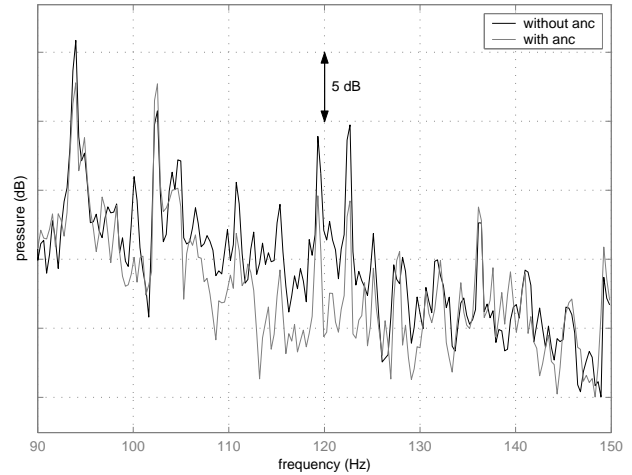

Figure 5: Autopowerspectra of the noise inside the cabin with and without feedforward control (microphone under the cabin as reference signal)

dominant part in the spectra inside the cabin. Figure 5 represents the auto power spectra of the noise at the left ear of the driver without and with feedforward noise control with the microphone under the cabin as the reference signal (the shape of the autopowerspectra at the right ear looks the same). It is clear that, by applying feedforward control, the noise level is reduced almost over the total considered frequency range.

The best reductions were achieved at the peak frequencies, caused by the front tools, according to the highest coherence values between the reference signal and the noise inside the cabin. Table 1 shows the noise attenuation at the main peak frequencies.

frequency (Hz)	reduction (dB)
94	3.0
102	-2.0
119	4.3
122	5.5

Table 1: Reduction by feedforward control at the most important peak frequencies

Every peak frequency caused by the front tools is reduced by at least 3 dB. Only at the peak of 102 Hz, there is no reduction but even a small amplification of the noise level. The reason is that the fan, at the backside of the machine causes this peak. This noise enters the cabin through the back and the side windows. Hence, it is not present in the signal of the reference microphone under the floor of the cabin and will not be reduced.

Figure 6 represents the reduction by feedforward

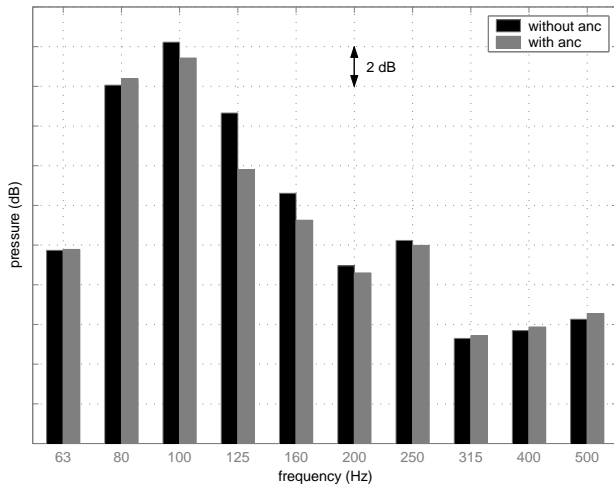

Figure 6: Noise level in 1/3 octave bands with and without feedforward control (microphone under the cabin as reference signal)

control in every 1/3 octave band over a broader frequency range. Note that the reference signal was filtered so there is only control effort and attenuation of the noise level in the frequency range from 90 to 200 Hz.

To show the importance of a good reference signal, figures 7 and 8 represent the autopowerspectra and the noise level in 1/3 octave bands, when a microphone at the backside of the harvester machine was used as the reference signal. It is clear that because of the worse coherence with the noise in the cabin, less reduction is achieved with this reference signal in comparison with the microphone under the cabin as the reference signal (figure 8). There is less attenuation of the noise level at the peak frequencies, except at the peak of 102 Hz, caused by the fan at the backside of the machine (figure 7).

## 2.3 Conclusions

The results for the feedforward control depend mainly on the quality of the reference signal. In a complex noise field, in this case generated by a harvester machine, it is difficult to find a good reference signal. Intensity scans and coherence measurements can give indications about the noise sources and, in this way, lead to the most suitable reference signal. Even with the best reference signal, in this case a microphone signals under the cabin, only reductions of 3 dB could be achieved.

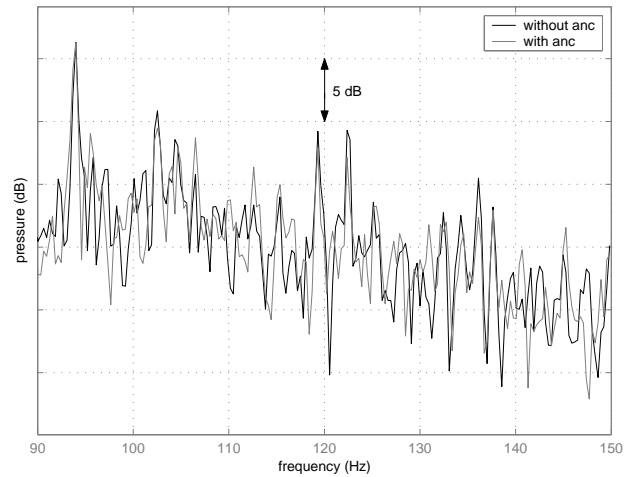

Figure 7: Autopowerspectra of the noise inside the cabin with and without feedforward control (microphone at the backside of the machine as reference signal)

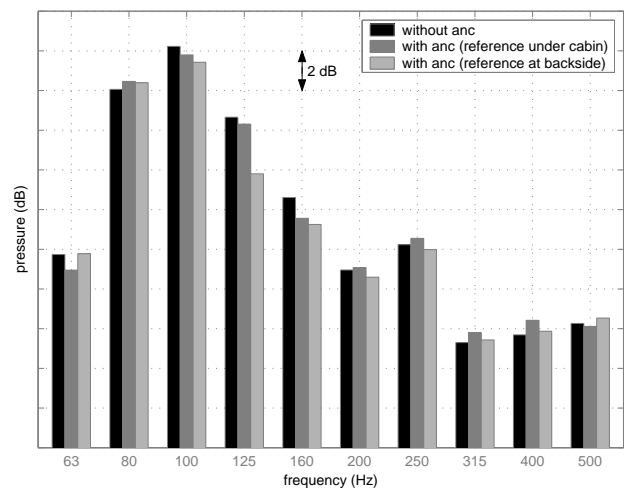

Figure 8: Noise level in 1/3 octave bands with and without feedforward control (microphone under the cabin and microphone at the backside of the machine as reference signal)

## 3 Feedforward control with feedback compensation

In the previous section, the poor coherence between the reference signal and the noise near the ears of the driver was the restriction for good results. In this section, a reference sensor inside the cabin, with a higher coherence, was used. Because the main part of the noise enters the cabin through the front window (figure 3), a microphone in the front side of the cabin was chosen as reference signal.

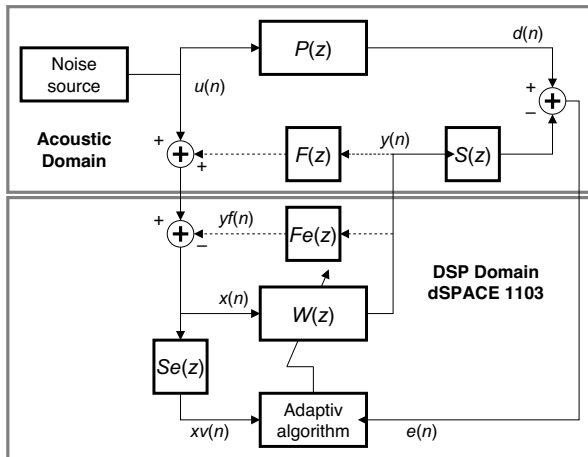

Figure 9: Feedforward ANC system with feedback neutralization

### 3.1 Algorithm

Using a microphone as reference sensor in the same acoustic enclosure where the secondary sources are placed can be problematic because of the feedback effect. The reference signal is influenced by the noise from secondary loudspeakers. Therefore, the control should be done by a feedforward ANC system with feedback compensation, as depicted on figure 9 (the dashed lines show the feedback effect and its compensation). As can be seen, the output signal of the system ( $y(n)$ ) through the secondary sources results in a disturbance in the signal measured by the reference microphone.  $u(n)$  is the primary noise source,  $x(n)$  is the signal picked up by the reference sensor and  $d(n)$  is the disturbance, sensed by the error microphone.  $F(z)$  is the transfer function of the feedback path from the output of adaptive filter to the reference signal.  $P(z)$  denotes the primary,  $S(z)$  the secondary transmission path as usual in ANC terminology [8].

The simplest approach to solving the feedback problem is to use a feedback neutralization filter within the controller: an adaptive filter ( $Fe(z)$ ) was used to identify the transfer path from the secondary source signal to the reference signal. The operation of the system consists of two main parts. During the off-line operation mode, the system identifies not only the secondary transmission paths, as in a traditional feedforward system, but also the feedback paths by using an LMS algorithm. When the system sends out signals to secondary sources, the influence on the reference signal can be calculated and compensated based on the previous estimation process. Note that  $F(z)$  is a potential source of instability.

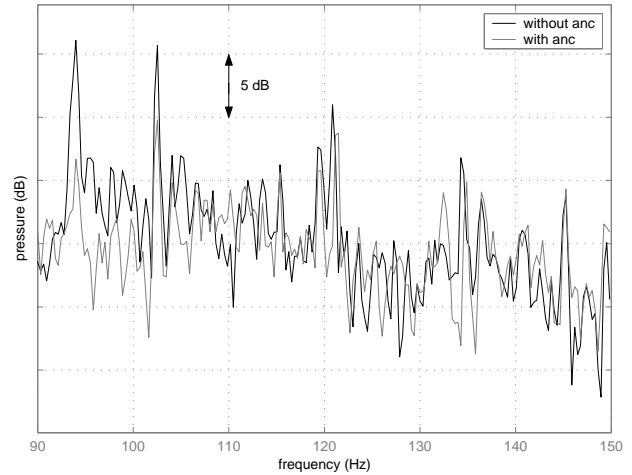

Figure 10: Autopowerspectra of the noise inside the cabin with and without feedforward control (feedback compensation)

### 3.2 Results

The set up for experiments was the same as previously mentioned in section 2. Figure 10 shows the autopowerspectra of the noise at the left microphone with and without feedforward control. Table 2 shows that now, unlike the case with the reference signal outside the cabin, reduction of the noise level was measured at all the peak frequencies mentioned previously. There was even reduction at the peak of 102 Hz, because this noise, that enters the cabin through the back and the side windows as mentioned before, is now also measured by the reference microphone.

frequency (hz)	reduction (dB)
94	10.1
102	5.9
119	1.9
122	2.3

Table 2: Reduction by feedforward control at the most important peak frequencies (feedback compensation)

In order to achieve better coherence between the reference signal and the error signals the reference microphone was placed as near as possible to the error microphone. However, system causality sets the limit to this distance. The results of the measurements at the new closer position can be seen in figure 11. As one can see, good reductions were now achieved over a broader band between 90 and 120 Hz. Also good results were measured at the peaks of 94 Hz and 102 Hz. However, less attenuation was achieved at the peaks at 119 Hz and 122 Hz. These noise peaks come from

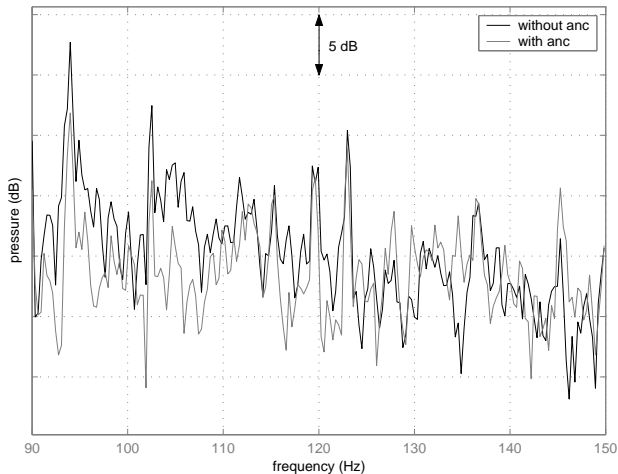

Figure 11: Autopowerspectra of the noise inside the cabin with and without feedforward control (feedback compensation, closer position)

the front tools into the cabin and were better measured by the reference microphone in the front side of the cabin.

The 1/3 octave band representation of the two reference microphone arrangements in the cabin is shown in Figure 12, the second and the third bar series shows the result of controllers respectively. The best reduction is achieved in the second arrangement with the reference microphone closer to the error microphone. The maximum reduction of this second arrangement is approximately 4 dB at the 100 Hz band. This result is better than the result of the standard feedforward system in the previous section. The reduction of the noise in the first arrangement is smaller, but in this case, the disturbing peaks are attenuated to a lower level.

### 3.3 Conclusions

As one can see, a better reference signal could be found inside the cabin. The reference signal can even further be improved by positioning it closer to the error microphone, but even then the coherence remained low at two important peaks. An adaptation of the feedforward algorithm was necessary to compensate for the feedback path of the secondary loudspeakers to the reference signal. The disadvantages of feedforward systems (e.g. the quality of reference signal that determines the result) were experienced again.

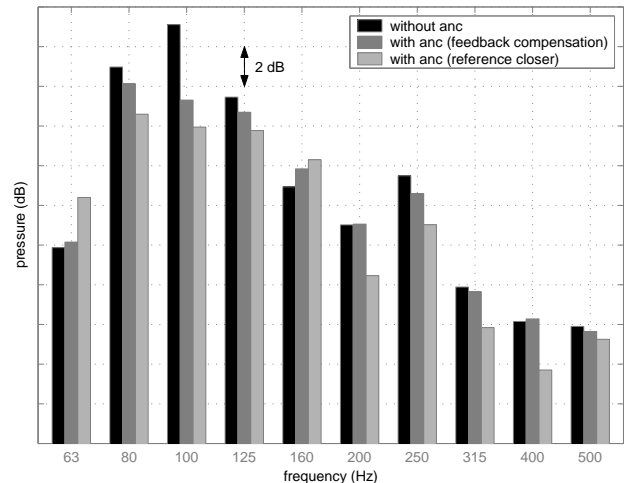

Figure 12: Noise level in 1/3 octave bands with and without feedforward control (feedback compensation)

## 4 Feedback control

This paragraph deals with the feedback control of the harvester machine. The control was developed based on an input-output approach. A state-space variable model could not be used, because the modelling of the acoustical transfer path between the secondary loudspeakers and the error microphones is too difficult. In a first part the optimal controller for a SISO (single input single output) system, consisting of a loudspeaker and an error microphone at one side of the driver, is discussed. A second part investigates the coupling effects when the left and right SISO systems are combined into one MIMO (multiple input multiple output) system. Finally, some conclusions about the feedback system are presented.

### 4.1 SISO - system

In this part, a controller for the left ear system is developed. A controller for the right ear system was developed in an analogous way. Figure 13 represents the amplitude of the transfer function between the input voltage of the left loudspeaker and the output voltage of the left error microphone, both in the same position as in the feedforward system. The state variable model for this transfer function is too complicated to identify because of the great amount of acoustical modes of the cabin. Therefore, the controller is developed using an input-output approach, directly based on this measurement of the transfer function.

First, a proportional-integral controller is used to

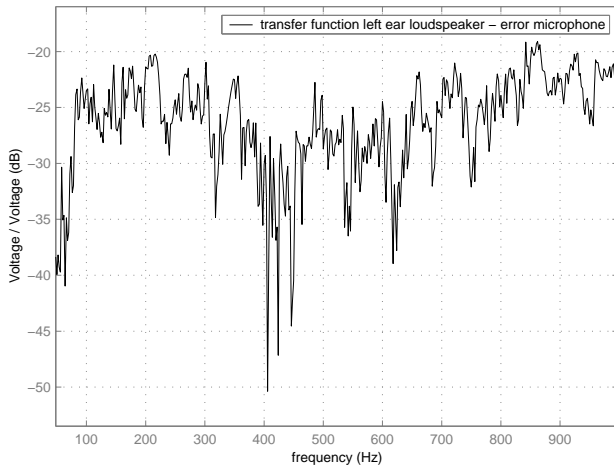

Figure 13: Amplitude of the transfer function between the secondary loudspeaker and the error microphone

close the loop of the transfer function. In a next step, this controller is adapted with a lead-lag compensator. The main problem, for the feedback system, is the limited bandwidth due to the time delay, the presence of acoustical modes and the dynamics of the transducers. However, because the disturbing noise is low-frequency in this case, good results can still be achieved by feedback control. The time delay is reduced by placing the loudspeaker closer to the error microphone. In this way, the bandwidth and, consequently, the achievable low-frequency noise reduction are increased. In the limit, when the microphone is placed against the loudspeaker, an active headset is realized. For an active headset, the minimum distance between the loudspeaker and the error microphone is limited to the transition of the diffuse field of the loudspeaker in the cabin to the direct field. When the loudspeaker is too close to the error microphone, the noise attenuation will be too local (no noise reduction at distances larger than 5 cm from the error microphone); when the microphone is placed in the diffuse field, the global acoustic modes of the cabin will be excited and the generated zone of quiet will be wider (quite good noise reduction further than 5 cm remote from the error microphone). The local reduction is no problem in an active headset, because the relative position of the driver's ear and the error microphone remains the same. However, active headsets are not popular amongst the drivers and were therefore not considered in this paper.

Figure 14 shows the open loop transfer function  $\frac{P(s)}{s}$  of the loudspeaker-microphone transfer function and the integrator, when the microphone is placed in

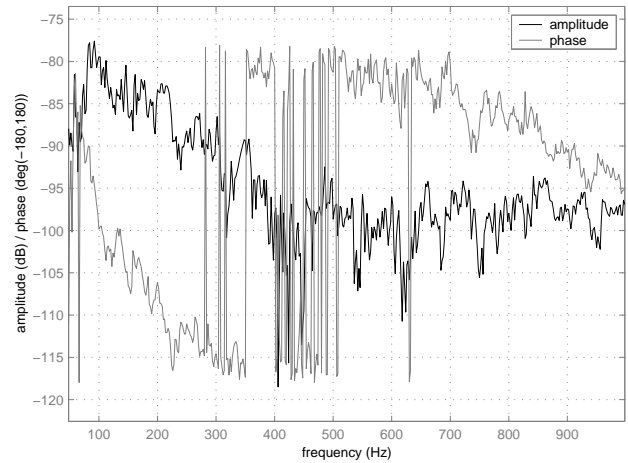

Figure 14: Amplitude and phase of the open loop transfer function

the transition zone between the direct and the diffuse field. The best noise attenuation in the low-frequency range is achieved by increasing the gain factor  $K$  of the proportional controller until the stability limit, defined by the Nyquist criterion ( $K_{max}$ ). However, in this case, the amplification of the higher frequency noise ( $S$ ) will become too high, because of the positive feedback when the open loop phase shift approaches  $180^\circ$ :

$$S = \frac{1}{1 + \frac{KP}{s}} \quad \text{and} \quad \frac{KP}{s} \approx -1$$

Hence, the gain factor of the proportional controller was limited to  $\frac{1}{5}K_{max}$  so that the amplification of higher frequency noise is restricted to  $20 \log\left(\frac{1}{1-\frac{1}{5}}\right) = 2$  dB. Figure 15 shows the noise reductions and amplifications in different  $1/3$  octave bands for a proportional gain  $\frac{1}{5}K_{max}$  and a gain  $K_{max}$ . Although the best reduction at low frequencies is achieved with  $K_{max}$ , a proportional gain  $\frac{1}{5}K_{max}$  gives better results over the whole frequency spectrum. With a gain  $K_{max}$ , the higher frequencies are strongly amplified and become dominant. Next to this, with a proportional gain  $\frac{1}{5}K_{max}$  the gain margin of the controller is higher and the system will be more robust to changes in the acoustical transfer function.

The ideal controller should have a high gain factor at low frequencies (good noise reduction) and a small gain factor at higher frequencies (small amplification). This is exactly the frequency-response characteristic of a lead lag compensator, which was added to the simple proportional-integral controller, resulting in the controller represented in figure 16. An extra reduction ( $\pm 1$  dB) of the low frequencies was possible for the same amplification of the high frequencies



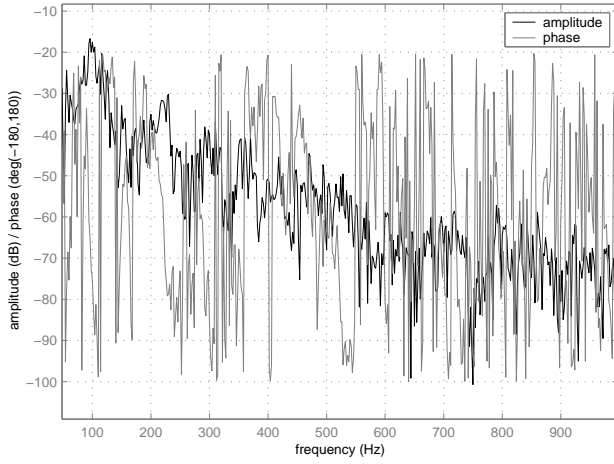

Figure 19: Amplitude and phase of the transfer function of the third loop  $C_1P_{LR}C_2P_{RL}$  in the MIMO-system

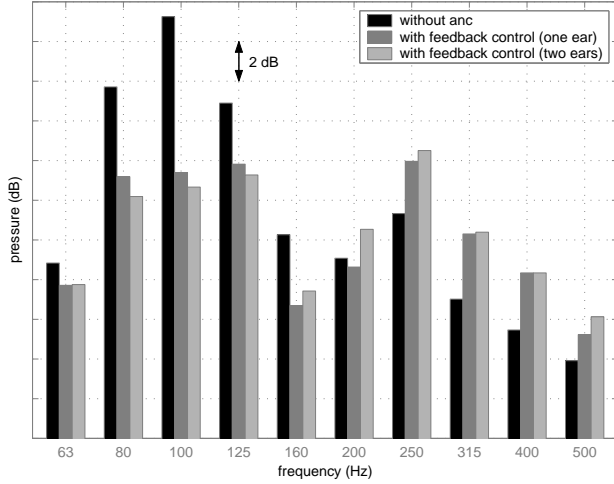

Figure 20: Noise level in 1/3 octave bands without control, with feedback control at one ear, with feedback control at two ears

loop  $C_1P_{LR}C_2P_{RL}$  (figure 19) shows that this loop is also stable.

Figure 20 shows the difference of the noise reduction at the left ear when only the left SISO-system is turned on and when the total MIMO-system is in operation. At low frequencies (100 Hz), there's an extra noise attenuation, when the right system is also turned on. However, at higher frequencies (200 Hz) the noise level is higher for the MIMO-system. This can be explained considering the expressions for the perceived noise at the left and right ear error microphones  $x_L$  and  $x_R$ .

$$x_L = d_L - C_L P_{LL} x_L - C_R P_{RL} x_R$$

$$x_R = d_R - C_R P_{RR} x_R - C_L P_{LR} x_L$$

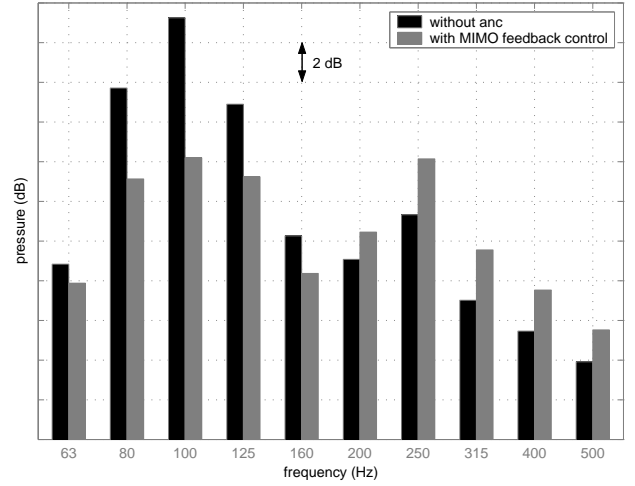

Figure 21: Noise level in 1/3 octave bands without control and with MIMO feedback control

Using these equations, the perceived noise at the left ear error microphone  $x_L$  can be expressed in terms of the noise disturbances  $d_L$  and  $d_R$ , generated by the harvester machine at the left and the right ear:

$$x_L = \frac{d_L - \frac{C_R P_{LR}}{1 + C_R P_{RR}} d_R}{1 + C_L P_{LL} - \frac{C_L C_R P_{LR} P_{RL}}{1 + C_R P_{RR}}}$$

At low frequencies, this expression can be simplified:

$$1 + C_L P_{LL} \gg \frac{C_L C_R P_{LR} P_{RL}}{1 + C_R P_{RR}}$$

↓

$$x_L = \frac{d_L - \frac{C_R P_{LR}}{1 + C_R P_{RR}} d_R}{1 + C_L P_{LL}}$$

Because the wavelength is high at low frequencies, the disturbances  $d_L$  and  $d_R$  are highly correlated ( $d_L - \frac{C_R P_{LR}}{1 + C_R P_{RR}} d_R < d_L$ ) and there will be an extra reduction for one SISO-system because of the other SISO-system.

At higher frequencies, the correlation of the disturbances is much lower ( $d_L - \frac{C_R P_{LR}}{1 + C_R P_{RR}} d_R > d_L$ ) and the negative term  $-\frac{C_L C_R P_{LR} P_{RL}}{1 + C_R P_{RR}}$  becomes also significant, so that the noise level will be higher in the MIMO-system than in the SISO-system. To reduce the noise level at higher frequencies, a reduction of the gain factors of the proportional amplifiers of the two SISO-controllers is necessary. In this way, the best results are achieved and they are represented on figure 21.

### 4.3 Conclusions

The achievable noise reduction, by a MIMO-control system, at the disturbing low-frequency range is 7 dB, which is higher than with feedforward control. Not only the noise levels at the peaks are reduced, but there is an overall attenuation at the low frequencies. Besides, no reference signal (difficult to find) and no offline identification of different transfer paths are necessary. The possible instability of a feedback system, the amplification of higher frequencies are restrictions in comparison with the feedforward system. The current audio loudspeakers, which can be used in the feedforward system, should also be replaced in the case of feedback control, because the distance between the secondary loudspeakers and the error microphones must be limited.

## 5 Conclusion

The demands for the sound comfort of the driver inside cabins of agricultural machines are continuously growing. To reduce the noise level in these machines, it is important to try and use in first instance traditional, passive noise control techniques instead of the more expensive, active techniques. However, when all the possible passive control techniques are used, the remaining part of the noise inside the cabin is low-frequency and can be controlled actively. This article deals with the active control of a typical agricultural machine, a harvester machine. Because the application of passive control techniques was already studied extensively in this case, the disturbing noise in the cabin was mainly low-frequency.

Three different active control techniques to reduce this low-frequency cabin noise are compared: feedforward control, feedforward control with feedback compensation and feedback control. For this application, the best results were achieved with feedback control. Because of the complexity of the noise field, generated by the machine, it is difficult to find an appropriate reference signal for both feedforward systems, with and without feedback compensation. Intensity scans and coherence measurements were used to find the best reference signal. Even with this best reference signal, the noise level could only be reduced with at most 4 dB by feedforward control.

The main difficulty for acoustical feedback systems is the design of a stable controller due to the time delay. In this application, the distance between the secondary loudspeakers and the error microphones

can be chosen rather small. This results in a stable system with a bandwidth of 175 Hz, which is high enough to reduce the low-frequency noise in the cabin. The low-frequency noise level can be attenuated with 7 dB.

Future work in this research area can be done in two domains. First, the possibilities of a hybrid strategy, combining feedforward and feedback control, can be investigated [10]. Next to this, the relatively new control technique Active Structural Acoustic Control can be tested. In this control strategy, structural exciters on the side walls and the windows of the cabin, reducing the radiated sound power, are used as secondary actuators instead of loudspeakers.

## Acknowledgements

This research was partly funded by the Belgian Ministry of Small Enterprises, Traders and Agriculture (DG 6).

## References

- [1] A.M. Abd-El-Tawwab, S.A. Abouel-Seoud, F.M. El-Sayad, T.A. Abd-El-Hakim, "Characteristics of Agriculture Tractor Interior Noise", *Journal of Low Frequency Noise, Vibration and Active Control*, Vol. 19, No. 2, MultiScience Publishing (2000), pp. 73-81.
- [2] J.-P. Bardon, "Acoustical study of a truck cab", in *Proceedings of the First European Forum on Materials and Products for Noise and Vibration Control in Machinery and Transportation*, Senlis, France, 2001 July 3-5, CETIM (2001), Vol.1, pp. 297-303.
- [3] B. Pluymers, W. Desmet, P. Sas, "Experimental and numerical tools for the evaluation of the sound insulation characteristics of the cabin of a combine harvester", *Proceedings of the First European Forum on Materials and Products for Noise and Vibration Control in Machinery and Transportation*, Senlis, France, 2001 July 3-5, CETIM (2001), Vol.1, pp. 316-327.
- [4] A.F. Seybert, J. Shi, A. Charan, "Assessment of Numerical Models and Methods for Noise Radiation Prediction", in *Proceedings of the SAE Noise and Vibration Conference and Exposition*, Traverse City, Michigan, USA, 2001 April 30 - May 3, Number: 2001-01-1520.

- 
- [5] X. Carniel, M. Besombes, "Des cabines plus silencieuses", *CETIM-Informations*, No. 174, July 2001, pp. 31-33.
- [6] B. Widrow and S. D. Stearns, *Adaptive Signal Processing*, Prentice-Hall, Englewood Cliffs, NJ (1985).
- [7] Product page of dSPACE ControlDesk, 2002 (<http://www.dspace.de/en/products/experiSW.htm>)
- [8] S. M. Kuo and D. R. Morgan, *Active noise control systems: algorithms and DSP implementations*, John Wiley & Sons, New York (1996).
- [9] S. Haykin, *Adaptive Filter Theory*, Prentice Hall, Upper Saddle River, New Jersey (1996).
- [10] W.-K. Tseng, B. Rafaely, S.J. Elliott, "Combined feedback-feedforward active control of sound in a room", *Journal of the Acoustical Society of America*, Vol. 104, No. 6 (1998), pp. 3417-3425.

